

**MARKET LEADER**  
**BUILT TOUGH**

**ACCESS  
EXPRESS®**



PAGE



(08) 6159 4600 | (08) 8112 3700 [www.accessexpress.com.au](http://www.accessexpress.com.au)

WA

SA



**MARKET LEADER**  
**BUILT TOUGH**

**ACCESS  
EXPRESS®**

## Mobile Aerial Stock Picker

### PARAMETER

| Model                         | DYT 2-2.7S  | DYT 2-3.7SW | DYT 2-4.5S  |
|-------------------------------|-------------|-------------|-------------|
| S.W.L                         | 300kg       | 300kg       | 300kg       |
| Max. Occupants                | 1           | 1           | 1           |
| Max. Working Height <b>A</b>  | 4.70m       | 5.70m       | 6.50m       |
| Max. Platform Height <b>B</b> | 2.70m       | 3.70m       | 4.50m       |
| Overall Length <b>C</b>       | 1.38 m      | 1.38m       | 1.42m       |
| Overall Width <b>D</b>        | 1.06 m      | 1.06m       | 1.08m       |
| Overall Height <b>E</b>       | 1.89 m      | 2.39m       | 2.28m       |
| Platform Size(Length×Width)   | 0.64m×0.80m | 0.64m×0.80m | 0.64m×0.80m |
| Ground Clearance              | 0.08m       | 0.08m       | 0.08m       |
| Wheelbase                     | 0.92m       | 0.92m       | 0.95m       |
| Lifting Motor                 | 12VDC/1.6kW | 12VDC/1.6kW | 12VDC/1.6kW |
| Up/Down Speed                 | 22/12sec    | 33/18sec    | 30/17sec    |
| Max. Working Slope            | 1°          | 1°          | 1°          |
| Batteries                     | 2×12V/85Ah  | 2×12V/85Ah  | 2×12V/85Ah  |
| Integrated Charger            | 12V/30A     | 12V/30A     | 12V/30A     |
| Tyres(Front Wheels)           | 6in         | 6in         | 6in         |
| Tyres(Back Wheels)            | Φ152×55mm   | Φ152×55mm   | Φ152×55mm   |
| Weight                        | 460kg       | 490kg       | 605kg       |

### Standard Equipment

- Emergency Lowering System
- Battery Charge Indicator
- Two Brakes And Two Brake Pads
- Voltage Indicator
- Safety Bracket
- Drawal Type Battery Box
- Emergency Stop Button
- All Motion Alarm
- Flashing Beacon
- Flat Platform
- Cylinder Holding Valve
- Tilt Sensor With Alarm
- Onboard Diagnostic System
- Overload Sensor With Alarm

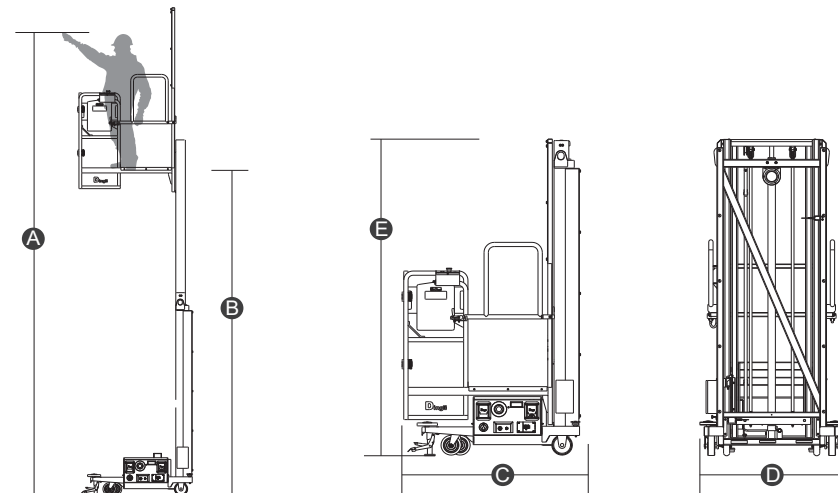

(08) 6159 4600 | (08) 8112 3700 [www.accessexpress.com.au](http://www.accessexpress.com.au)

WA

SA

