



## SPECIFICATIONS

Size	Metric	British
Max. Working Height <b>A</b>	9.50m	31ft 2in
Max. Platform Height <b>B</b>	7.50m	24ft 7in
Overall Length <b>C</b>	1.30m	4ft 3in
Overall Width <b>D</b>	0.75m	2ft 6in
Overall Height <b>E</b>	1.99m	6ft 6in
Outrigger Footprint(Length <b>F</b> /Width <b>G</b> )	1.70m/1.86m	5ft 7in/6ft 1in
Platform Size(Length×Width)	0.70m×0.60m	2ft 4in×2ft
Ground Clearance	0.055m	2in
Tyres(Front)	0.20m	8in
Tyres(Back)	0.13m	5in

Performance		
S.W.L	150kg	330lb
Max. Occupants	1	1
Up/Down Speed	28/18sec	28/18sec

Weight		
Weight - AC	430kg	947lb
Weight - DC	453kg	998lb

Power		
Battery	12V/85Ah	12V/85Ah
Charger	12V/15A	12V/15A
Lifting Motor - AC	220VAC/1.5kW	220VAC/1.5kW
Lifting Motor - DC	12VDC/1.5kW	12VDC/1.5kW

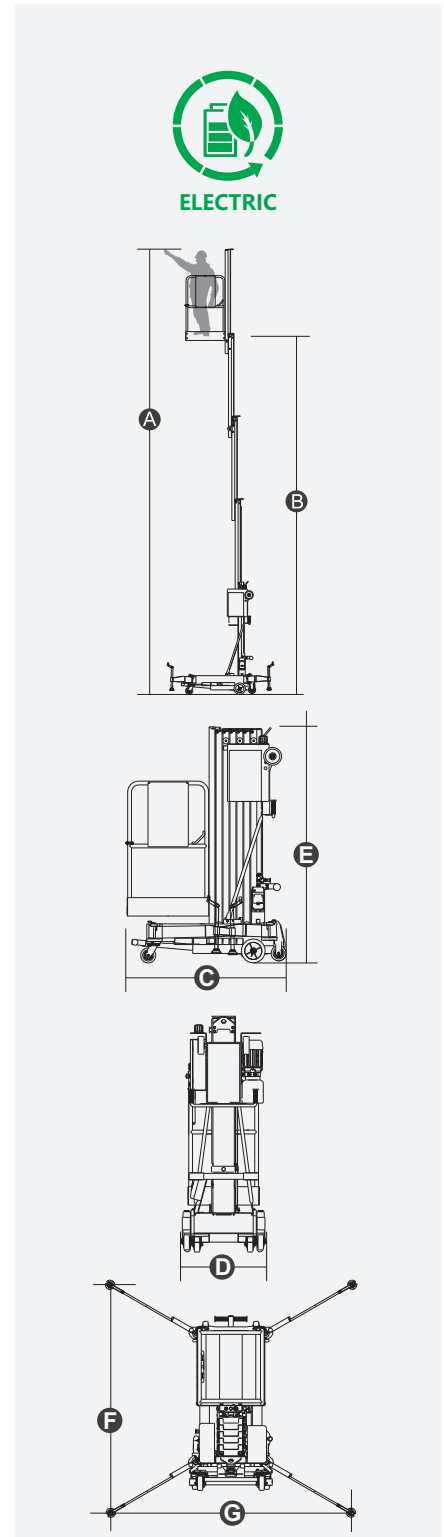



## FEATURES

### Standard Items

- Self-Locking Gates
- Emergency Descent System
- Tubing Explosion-Proof System
- Motion Alarm
- Charging Indicator(DC type)
- Charging Protection System(DC type)
- Flashing Beacon
- Lanyard Attachment Point
- Tie-Down And Lifting Points
- Emergency Stop Button

