

SPECIFICATIONS

Size	Metric	British
Max. Working Height A	12.50m	41ft
Max. Platform Height B	10.50m	34ft 5in
Overall Length(Stowed) C	1.53m	5ft
Overall Length(Tilted Back) D	2.63m	8ft 8in
Overall Width E	0.75m	2ft 6in
Overall Height(Stowed) F	2.35m	7ft 9in
Overall Height(Tilted Back) G	1.70m	5ft 7in
Outrigger Footprint(Length H /Width I)	2.08m/2.15m	6ft 10in/7ft 1in
Platform Size(Length×Width)	0.70m×0.60m	2ft 4in×2ft
Ground Clearance	0.055m	2in
Tyres(Front)	0.20m	8in
Tyres(Back)	0.13m	5in

Performance		
S.W.L	150kg	330lb
Max. Occupants	1	1
Up/Down Speed	40/26sec	40/26sec

Weight		
Weight - AC	530kg	1168lb
Weight - DC	553kg	1219lb

Power		
Battery	12V/85Ah	12V/85Ah
Charger	12V/15A	12V/15A
Lifting Motor - AC	220VAC/1.5kW	220VAC/1.5kW
Lifting Motor - DC	12VDC/1.5kW	12VDC/1.5kW

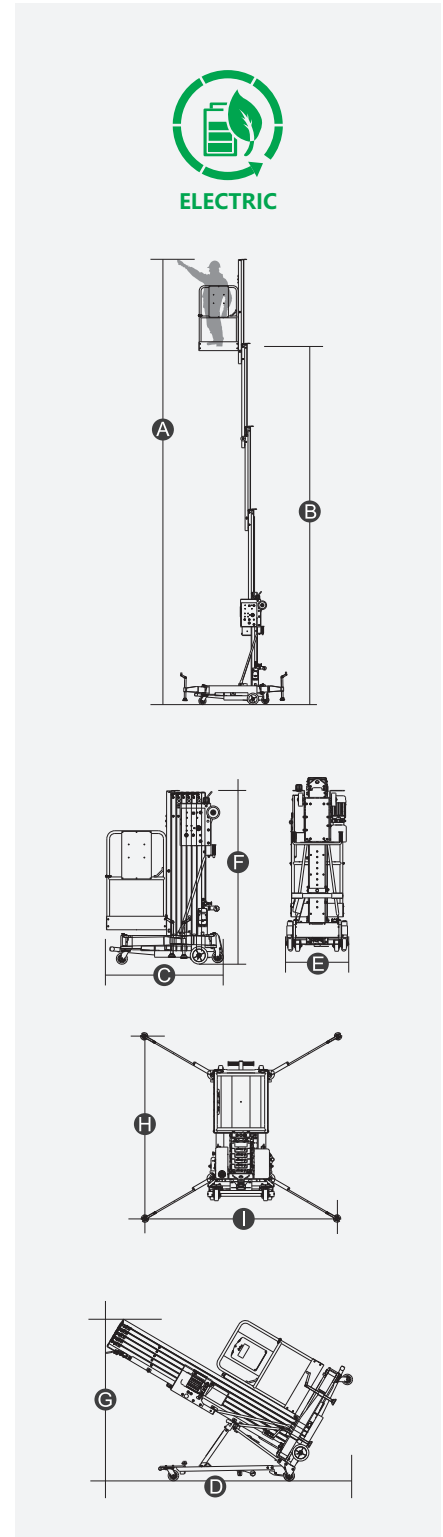



FEATURES

Standard Items

- Self-Locking Gates
- Emergency Descent System
- Tubing Explosion-Proof System
- Motion Alarm
- Charging Indicator(DC type)
- Charging Protection System(DC type)
- Flashing Beacon
- Lanyard Attachment Point
- Tie-Down And Lifting Points
- Emergency Stop Button

