

SPECIFICATIONS

Size	Metric	British
Max. Working Height A	14.30m	46ft 11in
Max. Platform Height B	12.30m	40ft 4in
Overall Length(Without Outriggers)	3.19m	10ft 6in
Overall Length(With Outriggers) C	3.84m	12ft 7in
Overall Width D	1.76m	5ft 9in
Overall Height(Rails Up) E	2.74m	9ft
Overall Height(Rails Down) F	1.97m	6ft 6in
Platform Size(Length×Width)	2.88m×1.52m	9ft 5in × 5ft
Platform Extension Size G	1.43m	4ft 8in
Ground Clearance(Stowed/Raised)	0.24m	9in
Wheelbase H	2.29m	7ft 6in
Turning Radius(Inside/Outside)	2.15m/4.85m	7ft 1in/15ft 11in
Tyres	26×12-16.5	26×12-16.5

Performance		
S.W.L	363kg	800lb
S.W.L On Extension	136kg	299lb
Max. Occupants	3	3
Gradeability	40%	40%
Travel Speed(Stowed)	5.0km/h	5.0km/h
Travel Speed(Raised)	0.45km/h	0.45km/h
Max. Working Slope	1.5°/3°	1.5°/3°
Up/Down Speed	45/46sec	45/46sec

Weight		
Overall Weight(Without Outriggers)	5050kg	11133lb
Overall Weight(With Outriggers)	5050kg	11133lb

Power		
Diesel Engine	18.6kW/2400rpm	18.6kW/2400rpm
Diesel Tank	47L	47L
Hydraulic Tank	71L	71L

* The platform height plus 2m (7ft in British standard) is the working height.
Standards Compliance

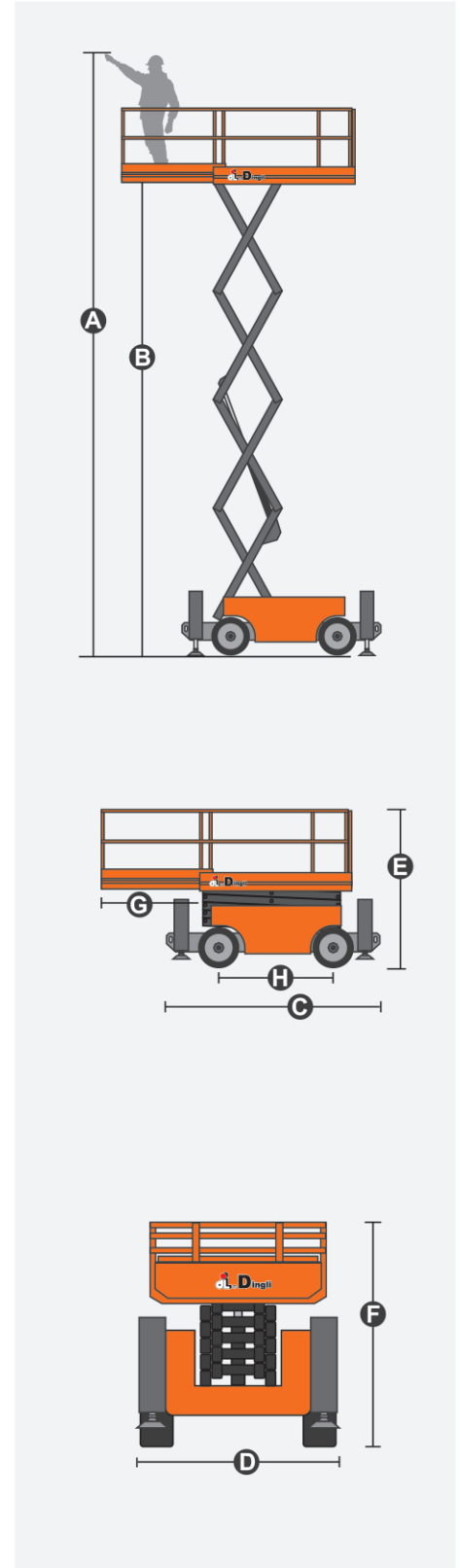

FEATURES

Standard Items

- Proportional Joystick Controls
- Self-Locking Gates
- One-Way Platform Extension Deck
- 4x4 Drive
- Drivable At Full Height
- Self-Weight Lowering System
- Tubing Explosion-Proof System
- Onboard Fault Diagnostic System
- Tilt Alarm
- Motion Alarm
- Horn
- Hour Meter
- Hydraulic Oil Cooling System
- Charging Protection System
- Flashing LED Beacon
- Foldable Guard Rails
- Drive Enable
- Platform Load Sense System
- Manual Brake Release
- Lanyard Attachment Point
- Standard Transport Forklift Pockets
- Automatic Leveling Hydraulic Outriggers
- Anti-Restart Engine Protection
- Oscillating Axle Chassis
- Emergency Stop Button

Optional Items

Factory Tyres

- Foam-Filled Tyres **
- Non-Marking Tyres

Factory Hydraulic Oil

- No. 46 Hydraulic Oil (Mineral Oil)**

Additional Items

- GPS Unit
- Biodegradable Hydraulic Oil
- AC Power Cord to Platform
- Air Line to Platform
- Work Light Package
- Footpedal Switch
- Anti-Collision Bar on Platform
- Visual Spirit Level
- Hydraulic Generator
- Oil-Water Separator
- Outrigger Pad Package