



SPECIFICATIONS

Size	Metric	British
Max. Working Height A	15.70m	51ft 6in
Max. Platform Height B	13.70m	44ft 11in
Overall Length C	2.48m	8ft 2in
Overall Width D	1.19m	3ft 11in
Overall Height(Rails Up) E	2.75m	9ft
Overall Height(Rails Down) F	2.22m	7ft 3in
Platform Size(Length×Width)	2.27m×1.12m	7ft 5in×3ft 8in
Platform Extension Size G	0.90m	2ft 11in
Ground Clearance(Stowed/Raised)	0.10m/0.019m	4in/1in
Wheelbase H	1.87m	6ft 2in
Turning Radius(Inside/Outside)	0m/2.20m	0in/7ft 3in
Tyres	φ381×127mm	φ381×127mm

Performance		
S.W.L	250kg	551lb
S.W.L On Extension	113kg	249lb
Max. Occupants	2	2
Gradeability	25%	25%
Travel Speed(Stowed)	3.5km/h	3.5km/h
Travel Speed(Raised)	0.8km/h	0.8km/h
Max. Working Slope	1.5°/3°	1.5°/3°
Up/Down Speed	76/60sec	76/60sec

Weight		
Overall Weight(Lead-acid Battery)	3190kg	7032lb
Overall Weight(Lithium Battery)	3100kg	6834lb

Power		
Hydraulic Tank	20L	20L
Battery	4×12V/240Ah	4×12V/240Ah
Charger	24V/30A	24V/30A
Lifting Motor	24VAC/3.5kW	24VAC/3.5kW

* The platform height plus 2m (7ft in British standard) is the working height.
Standards Compliance

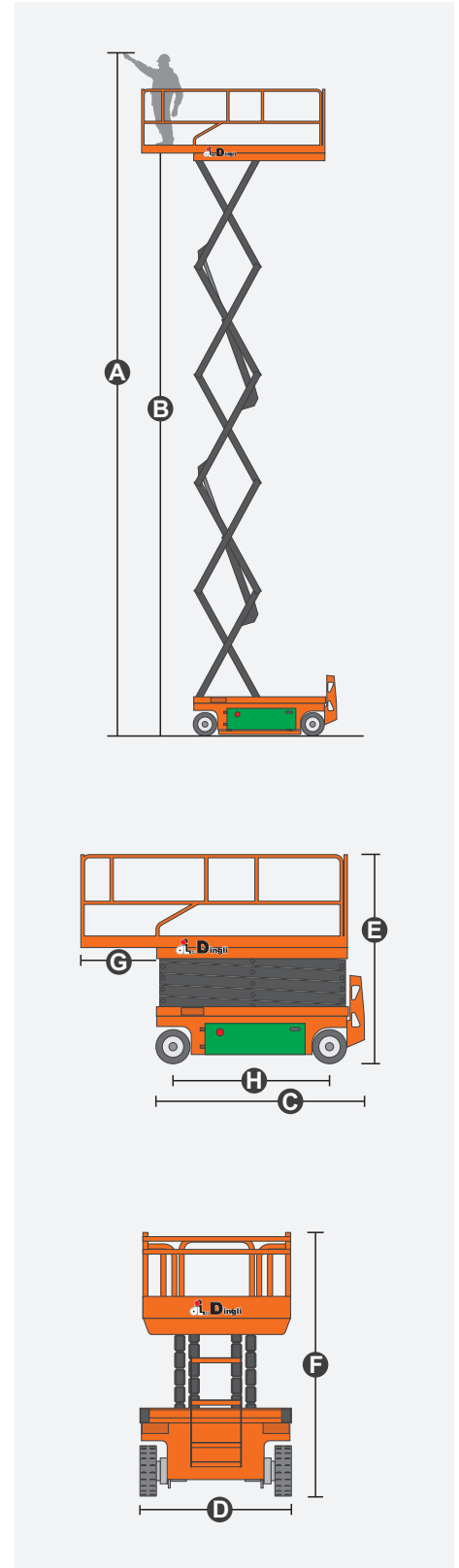



FEATURES

Standard Items

- Proportional Joystick Controls
- Self-Locking Gates
- One-Way Platform Extension Deck
- Drivable At Full Height
- Non-Marking Tires
- 4x2 Drive
- Four-Wheel Braking
- Emergency Descent System
- Tubing Explosion-Proof System
- Onboard Fault Diagnostic System
- Tilt Alarm
- Motion Alarm
- Horn
- Hour Meter
- Safety Arm For Troubleshooting
- Standard Transport Forklift Holes
- Charging Protection System
- Flashing LED Beacon
- Foldable Guard Rails
- Automatic Pothole Protection
- Drive Enable
- Automatic One-Way Platform Extension Deck
- Manual Brake Release
- Lanyard Attachment Point
- Tie-Down And Lifting Points
- Platform Load Sense System

Optional Items

Factory Battery

- Lead-Acid Battery **
- Lithium Battery

Factory Hydraulic Oil

- No. 46 Hydraulic Oil (Mineral Oil)**

Additional Items

- GPS Unit
- Biodegradable Hydraulic Oil
- AC Power Cord to Platform
- Air Line to Platform
- Work Light Package
- Footpedal Switch
- Anti-Collision Bar on Platform
- Ultrasonic Sensor on Platform

** Factory Default, If You Have Other Needs, Please Inform Dingli Regional Sales.