

Aerial Work Platforms

Genie® QuickStock™

Specifications

Models	QS-15W		QS-20W	
Measurements	Metric	US	Metric	US
Working height*	6.47 m	20 ft 8 in	8.02 m	25 ft 9 in
Platform height	4.47 m	14 ft 8 in	6.02 m	19 ft 9 in
A A Platform dimensions (length x width)				
With tray down	89 cm x 73 cm	35 x 28.8 in	89 cm x 73 cm	35 x 28.8 in
With tray up	1.42 m x 73 cm	56 x 28.8 in	1.42 m x 73 cm	56 x 28.8 in
A Height - stowed	1.57 m	5 ft 2 in	1.98 m	6 ft 6 in
A Length - stowed	1.35 m	4 ft 5 in	1.35 m	4 ft 5 in
A Width	75 cm	2 ft 5.5 in	80 cm	2 ft 7.5 in
A Ground clearance - center	6 cm	2.5 in	6 cm	2.5 in

Productivity

Max platform occupancy (indoor/outdoor) ¹			1/-	
Lift capacity	227 kg	500 lbs	159 kg	350 lbs
Work station tray capacity	68 kg	150 lbs	68 kg	150 lbs
Drive speed - stowed	4.0 km/h	2.5 mph	4.0 km/h	2.5 mph
Drive speed - raised	0.8 km/h	0.5 mph	0.8 km/h	0.5 mph
Gradeability**		30%		30%
Turning radius - inside		zero		zero
Turning radius - outside	1.32 m	4 ft 4 in	1.35 m	4 ft 5 in
Raise / lower speed	21 / 19 sec	21 / 19 sec	24 / 21 sec	24 / 21 sec
Controls	24V DC proportional		24V DC proportional	
Tyres - solid non-marking	25 x 8 x 20 cm	10 x 3 x 8 in	25 x 8 x 20 cm	10 x 3 x 8 in

Power

Power source	24V (four 6V 225 Ah maintenance-free batteries)			
Hydraulic system capacity	8.33 L	2.2 gal	8.33 L	2.2 gal

Sound & Vibration Levels

Sound pressure level (ground workstation)			<70 dBA	
Sound pressure level (platform workstation)			<70 dBA	
Vibration	<2.5 m/s ²	<8 ft 2 in/s ²	<2.5 m/s ²	<8 ft 2 in/s ²

Weight***

Weight	995 kg	2,194 lbs	1,122 kg	2,474 lbs
--------	--------	-----------	----------	-----------

Standards Compliance

AS 1418.10

¹ Indoor use only.

* The metric equivalent of working height adds 2 m to platform height. U.S. adds 6 ft to platform height.

** Gradeability applies to driving on slopes. See operator's manual for details regarding slope rating.

*** Weight will vary depending on options and/or country standards.

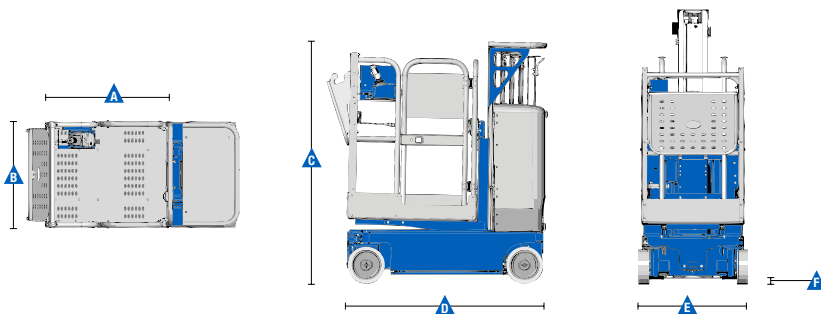

Aerial Work Platforms

Genie® QuickStock™

Features

Standard Features

Measurements

QS-15W

- 6.47 m (20 ft 8 in) working height
- 4.47 m (14 ft 8 in) platform height
- Up to 227 kg (500 lbs) lift capacity

QS™-20W

- 8.02 m (25 ft 9 in) working height
- 6.02 m (19 ft 9 in) platform height
- Up to 159 kg (350 lbs) lift capacity

Productivity

- Auxiliary platform lowering
- Low 39 cm (15.5 in) platform entry height
- Patented rigid mast system
- Enclosed platform cables
- Front folding tray
- Compact base 0.75 x 1.35 m (29.5 x 53 in) (QS-15 only)
- SmartLink™ control system
- Fully proportional lift and drive controls
- Battery charge indicator
- On-board diagnostic system
- Descent and tilt alarm
- Zero inside turning radius
- Dual wheel brakes
- Hydraulic brake release
- Pothole protection
- Hinged rear ABS covers for easy access to all major electrical and hydraulic components
- Tie down attachment points
- Overhead crane attachment point
- Large forklift pockets access
- Dual flashing beacons
- Motion alarm
- Drive cutout while charging
- Certified load sensor

Platform

- Stockpicker platform with dual side entry gates and front folding tray

Power

- 24V (four 6V 225 Ah maintenance-free batteries) with automatic 25 amp battery charger

Tyres

- Non-marking solid

Options & Accessories

Productivity

- 240V power to platform
- Biodegradable hydraulic oil

