

Self-Propelled Scissor Lifts

GS™-4047

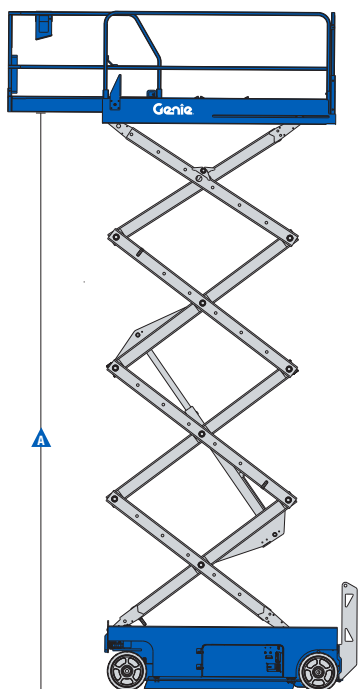
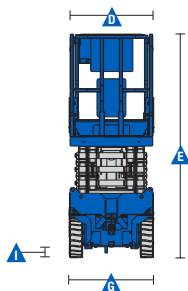
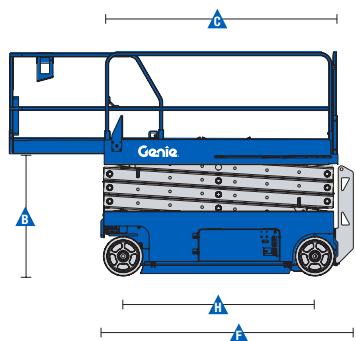

Specifications

Model	GS-4047	
Measurements	US	Metric
Working height maximum*	45 ft	13.89 m
▲ Platform height maximum	39 ft	11.89 m
▲ Platform height - stowed	4 ft 8 in	1.43 m
▲ Platform length - outside	7 ft 5 in	2.26 m
- extended	10 ft 5 in	3.18 m
▲ Platform width - outside	3 ft 10 in	1.16 m
▲ Height - stowed: folding rails	8 ft 4 in	2.54 m
- rails lowered	6 ft 5 in	1.95 m
▲ Length - stowed	8 ft 2 in	2.48 m
- extended	10 ft 5 in	3.18 m
▲ Width	3 ft 11 in	1.19 m
▲ Wheelbase	6 ft 1 in	1.85 m
▲ Ground clearance - center	3.75 in	0.1 m
- with pothole guards deployed	0.75 in	0.02 m
Slide-out platform extension deck	3 ft	0.91 m
Guardrail height	3 ft 7 in	1.09 m
Toeboard height	6 in	0.15 m

Productivity

Max platform occupancy	2	
Lift capacity	550 lbs	249 kg
Lift capacity - extension deck	250 lbs	113 kg
Drive height	Full height	
Drive speed - stowed	2.0 mph	3.2 km/h
Drive speed - raised	0.5 mph	0.8 km/h
Gradeability - stowed**	25%	
Turning radius - inside	zero	
Turning radius - outside	7 ft 7 in	2.31 m
Raise/lower speed	71/41 sec	
Controls	proportional	
Drive	dual front wheel	
Multiple disc brakes	dual rear wheel	
Tires solid non-marking	15 x 5 in	38 x 13 cm

Power

Power source	24 V DC, 300 Ah (four 12 V, 150 Ah batteries in parallel series)	
Hydraulic system capacity	7.5 gal	28.4 L

Weight***

Weight - ANSI/CSA	7,185 lbs	3,260 kg
Tire load, maximum:	2,621 lb	1,189 kg
Tire contact pressure:	175 psi	1,205 kPa
Occupied floor pressure:	270 psf	12.91 kPa

Standards Compliance

ANSI A92.6, CSA B354.2, CE Compliance, AS 1418.10

¹ The metric equivalent of working height adds 2 m to platform height. U.S. adds 6 ft to platform height.

² Gradeability applies to driving on slopes. Gradeability may vary depending on the weight of options installed on machine. See operator's manual for details regarding slope ratings.

³ Weight will vary depending on options and/or country standards.

⁴ Note: Floor loading information is approximate and does not incorporate different option configurations. It should be used only with adequate safety factors.

Self-Propelled Scissor Lifts

GS™-4047

Features

Standard Features

Measurements

GS-4047

- 45 ft (13.89 m) working height
- Up to 550 lbs (249 kg) lift capacity

Productivity

- Drive at full height
- Folding rails with full height swing gate
- Smart Link™ - proportional lift and drive
- Platform control with battery charge indicator
- AC power to platform
- Universal 27A smart charger
- Lanyard attachment points
- Manual platform lowering valve
- Emergency stop at both platform and ground controls
- Rear wheel multiple disc brakes
- Front wheel hydraulic dynamic braking
- Manual hydraulic brake release
- Swing-out component trays
- Pothole guards
- Tilt level sensor with audible alarm
- Dual flashing LED beacons
- Descent alarm
- Electronic horn
- Hour meter
- Motion alarm

Power

- 24 V DC, 300 Ah (four 12 V 150 Ah batteries in parallel series)
- Universal 20 amp smart charger

Platform

- 7 ft 5 in x 3 ft 9.3 in (2.26 x 1.15 m) steel platform
- 3 ft 9.3 in (0.91 m) extension deck

Drive

- Dual front wheel hydraulic drive

Tires

- Solid non-marking

Options & Accessories

Productivity Options

- Air line to platform
- Automotive-style horn
- Platform control guard

Power Options

- Power inverter (120 V / 60 Hz)*
- Drive cutout while charging

