

TOUCAN 10E-L

MAST BOOM LIFT



Performance

Working height	10.10 m
Platform height	8.10 m
Working outreach	3.38 m
Up and over height	6.51 m
Swing (not continuous)	345°
Platform capacity ¹	200kg (2 persons indoor and 1 person outdoor)
Jib - overall length	1.60 m
Jib - range of articulation	126° (+65°/-61°)
Platform size standard platform (LxW)	0.70 x 0.90 m
Drive speed - lowered	5.5 km/h
Drive speed - elevated	0.75 km/h
Drive speed - full elevation	0.40 km/h
Turning radius (outside)	1.99 m
Turning radius (inside)	0.55 m
Gradeability	25%
Machine weight ²	2,600 kg

1. Capacity shown is maximum two persons indoor and one person outdoor (12.5 m/s wind speed)

2. Certain options or country standards may increase weight and/or dimensions.

Standard Specifications

Power

Electrical system	24V DC
Batteries (AGM)	24V - 260 A/hr
Charger	24V - 27A
Drive motors	Dual AC motors
Brakes	Disc

Hydraulic System

- Electrical (pump) motor 3kW 24V DC
- Hydraulic system 7.5 L

Tyres

- Tyres (non-marking solid) 406 x 125 mm

Standard Features

- 0.90 m x 0.70 m (L x W) steel platform
- Slide bar rear entry
- Full proportional drive and slew joystick control with integral thumb steer switch
- Mini joysticks provide proportional mast and jib lift/lower functions
- 1.60 m articulating jib
- Load sensing system
- Large tool tray
- Two wheel direct electric drive
- Brushless AC drive motors
- Auto power save when idle
- Low charge function cut-out
- On-board diagnostics with integral display
- Automatic rear wheel brakes
- Sculptured polyester hoods
- Heavy duty steel roller mast with 345° rotation
- Chain slack detection system
- 2.5 degree tilt alarm and indicator light
- Passive pothole protection system
- 0.99 m wide frame
- Lifting /tie down rings
- Ground control selector switch with key lock
- Battery discharge indicator
- Hour meter
- Horn
- Drive orientation system
- Lanyard anchor points
- Zenon strobe light
- Acoustic motion alarm
- Manual descent system



Accessories & Options

- 8 mm air line to platform
- Food Compatible Hydraulic Oil
- Low Temperature Hydraulic Oil
- AC Outlets to platform incl. ELCB
- Platform work lights 70W
- Synthetic Biodegradable Hydraulic Oil

TOUCAN 10E-L

MAST BOOM LIFT



Dimensions

All dimensions are approximate.

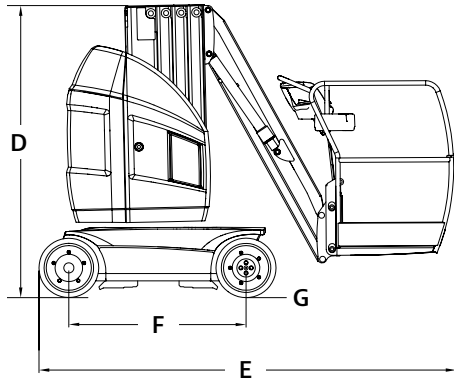

A. Platform size standard platform (L x W)	0.70 x 0.90 m
B. Overall width	0.99 m
C. Tailswing	12 cm
D. Stowed height	1.99 m
E. Overall length (standard platform)	2.82 m
F. Wheelbase	1.20 m
G. Ground clearance	10 cm

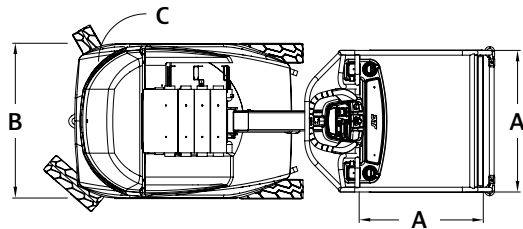

Reach Diagram

