

1250AJP

ULTRA SERIES BOOM LIFT



Performance

Platform Height	38.30 m
Working Height	40.30 m
Horizontal Reach	19.25 m
Up and Over Height	18.44
Swing	360° Continuous
Platform Capacity — Restricted	450 kg
Platform Capacity — Unrestricted	230 kg
Platform Rotator	180°
JibPLUS® Length	2.44 m
Horizontal Motion	125°
Vertical Motion	130° (+75/-55)
Weight	21,000 kg
Drive Speed - Lowered	5.2 km/h
Drive Speed - Elevated	0.5 km/h
Gradeability	45%
Turning Radius (Inside)	
Axles Retracted	4.39 m
Axles Extended	2.44 m
Turning Radius (Outside)	
Axles Retracted	6.86 m
Axles Extended	5.89 m

Standard Specifications

Power Source

Diesel Engine	
Deutz TD2011LO40 T4i	55 kW
Fuel Tank Capacity	117 L

Hydraulic System

- 202 L

Tyres

- Standard 445/50D710 24 Urethane-Filled

Standard Features

- Platform: 0.91 x 2.44 m Side Entry with Self-Closing Self-Locking Gate
- 2.44 m JibPLUS® Boom
- Selectable Capacity Envelope
- 180° Hydraulic Platform Rotator
- AC Receptacle in the Platform
- 5.5kVA Generator
- 1/2 in. Air Line to Platform
- 5 x 3 Degree Tilt Alarm/Indicator Light
- All Motion Alarm
- Swing-Out Engine Tray
- 12V DC Auxiliary Power
- Hourmeter
- Control ADE® System
- Full-time 4WD
- 3 Selectable Steering Modes
- Drive-out Extendible Axles
- Oscillating Axle
- Proportional Controls
- Gull-Wing Hoods
- 445/50D710 Urethane-Filled Rim Protector Lug Tread Tyres
- Platform Console Machine Status Light Panel*
- Lifting/Tie Down Lugs
- Engine Distress Warning/Shutdown—Selectable via JLG Analyzer

* Provides indicator lights at platform control console for system distress, fuel level, low fuel, 5 degree tilt light, and foot switch status.



Accessories & Options

- .91 x 1.83 m Platform Entry
- Mesh to Mid Rail
- Light Package¹
- Special Hydraulic Oils
- Console Cover
- Corner Storage Tray
- ClearSky®
- SkyGuard™
- Pipe Racks
- Cable Tray Carrier

1. Includes platform mounted worklights and drive/backup lights.

1250AJP

ULTRA SERIES BOOM LIFT



Dimensions

All dimensions are approximate.

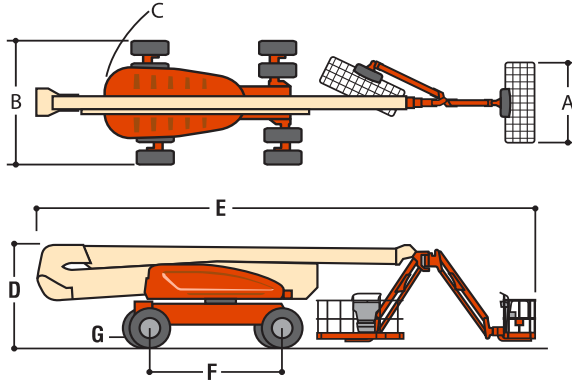

A. Platform Size	0.91 x 2.44 m
B. Overall Width Axles Retracted	2.49 m
Overall Width Axles Extended	3.81 m
C. Tailswing	0.91 m
D. Stowed Height	3.05 m
E. Overall Length Jib Stowed	11.46 m
Overall Length Jib Deployed	14.48 m
F. Wheel Base	3.81 m
G. Ground Clearance	
Axle	30 cm
Chassis	65 cm

Load Chart

