

ES SERIES

ELECTRIC SCISSOR LIFTS



Performance

Platform Height—Elevated	
1930ES	5.72 m
2032ES	6.10 m
2632ES	7.77 m
2646ES	7.92 m
3246ES	9.68 m
Platform Capacity	
1930ES	230 kg
2032ES	360 kg
2632ES	230/360 kg
2646ES	450 kg
3246ES	320/450 kg
Capacity on Platform Extension	
	120 kg
Lift/Lower Time	
1930ES	26/30 seconds
2032ES	28/40 seconds
2632ES	33/37 seconds
2646ES	41/50 seconds
3246ES	55/62 seconds
Maximum Drive Height	
	Fully Elevated
Weight*	
1930ES	1,575 kg
2032ES	2,000 kg
2632ES	2,145 kg
2646ES	2,765 kg
3246ES	2,940 kg
Drive Speed—Elevated	
	0.8 km/h
Drive Speed—Lowered	
1930ES	4.82 km/h
2032ES/ 2632ES	4.43 km/h
2646ES/ 3246ES	4.00 km/h
Gradeability	
	25%
Turning Radius (Inside)	
	Zero
Turning Radius (Outside)	
1930ES	1.75 m
2032ES/ 2632ES	2.06 m
2646ES/ 3246ES	2.41 m

* Certain options or country standards will increase weight.

Standard Specifications

Power Source

Batteries	4x6V 220 amp-hr	
Charger	20 Amp Automatic	
Drive	24V Electric	8hp

Hydraulic Reservoir

• Capacity	
1930ES/2032ES/2632ES	4.73 L
2646ES/3246ES	6.4 L
• Pump	
	Fixed Displacement Gear

Tyres

• Tyre Size/Type	
1930ES	12.5 x 4 in. Non-Marking Solid
2032ES/2632ES/2646ES/3246ES	16 x 5 in. Non-Marking Solid

Brakes

- Electric/Friction



Standard Features

- Proportional Controls
- Industry Leading Duty Cycles
- Self Closing and Locking Gate
- Battery Condition Indicator
- Fold-Down Guard Rails¹
- Slide-Out Battery Trays
- Automatic Traction Control (ATC)
- All Motion Alarm
- 20 Amp Automatic SCR Charger
- Horn
- Hourmeter
- Manual Descent Pull Cable
- Tilt Alarm and Light
- Moveable, Removable Platform Control
- Powder-Coated
- Console with Rail Mounting Bracket
- Nickel Plated Pins
- Lubrication Free Scissor Arm Bushings
- Scissor Maintenance Prop
- Mechanised Pothole Protection
- Machine Tie Downs
- Fork Lift Pockets, Lift from Side and Rear
- Flashing Amber Beacon
- Load Sensing System
- Lifting Lugs

Accessories & Options

- AC Outlet in Platform
- White Noise (squawker) Motion Alarm
- AGM Batteries
- Airtline to Platform
- Special Hydraulic Oils
- Accessory Packages:
 - Electrician's Package
 - Plumber's Package
 - JLG® Workstation
 - Panel Carrier Accessory¹
 - Pipe Rack Accessory¹
 - Plant Maintenance Package

¹ Not available on the 1930ES.

ES SERIES

ELECTRIC SCISSOR LIFTS



Dimensions

All dimensions are approximate.

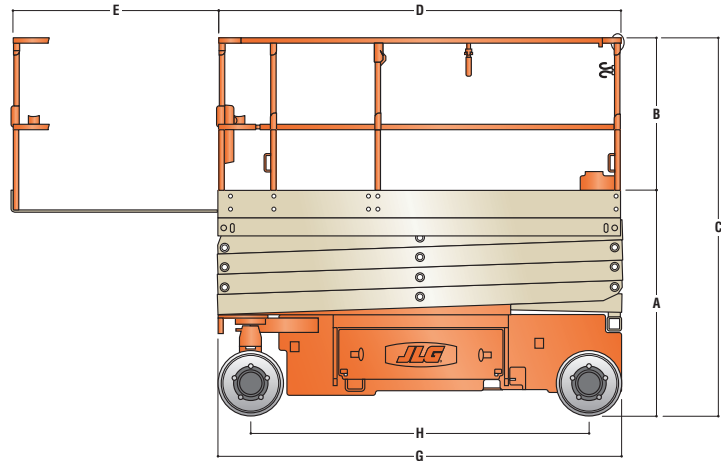
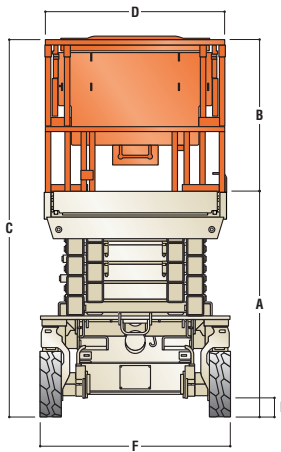

A. Platform Height-Lowered

1930ES	0.86 m
2032ES	1.10 m
2632ES	1.23 m
2646ES	1.26 m
3246ES	1.26 m

**B. Platform Railing Height
ES Series**

1.14 m

C. Overall Height-Rails Lowered

1930ES	N/A
2032ES	1.80 m
2632ES	1.94 m
2646ES/3246ES	1.97 m

D. Platform Size

1930ES	0.76 x 1.87 m
2032ES/2632ES	0.76 x 2.3 m
2646ES/3246ES	1.12 x 2.5 m

E. Platform Extension

1930ES/2032ES/2632ES	0.9 m
2646ES/3246ES	1.27 m

F. Overall Width

1930ES	76 cm
2032ES/2632ES	81 cm
2646ES/3246ES	1.17 m

G. Overall Length

1930ES	1.87 m
2032ES/2632ES	2.3 m
2646ES/3246ES	2.5 m

H. Wheelbase

1930ES	1.6 m
2032ES/2632ES	1.88 m
2646ES/3246ES	2.09 m

I. Ground Clearance

1930ES/2032ES/2632ES	8.8 cm
2646ES/3246ES	12.7 cm