

450 SERIES

ARTICULATING BOOM LIFT



Performance

Platform Height	45 ft	13.72 m
Horizontal Outreach		
450A	30 ft	9.14 m
450AJ	25 ft	7.62 m
Up and Over Height	24 ft	7.3 m
Swing	355 Degrees Non-Continuous	
Platform Capacity		
Unrestricted	550 lb	250 kg
Platform Size	30 x 72 in.	0.76 x 1.83 m
Platform Rotator	180 Degrees Hydraulic	
Jib	4 ft 1 in.	1.24 m
Range of Articulation	145 Degrees (+76, -69)	
Weight		
450A	15,850 lb	7,190 kg
450AJ	14,150 lb	6,418 kg
Max Ground Bearing Pressure	65 psi	4.57 kg/cm ²
Drive Speed	4.25 mph	6.84 km/hr
Gradeability		
2WD	30%	
4WD	45%	
Tilt Cut Out	5 Degrees	
Axle Oscillation	4 in.	10 cm
Turning Radius		
Inside	6 ft 9 in.	2.06 m
Outside	15 ft 8 in.	4.78 m

Standard Specifications

Power Source

Dual Fuel Engine		
Kubota WG2503	61 hp	45.5 kW
Diesel Engine		
Deutz D2.9 L4 Tier 4 Final	49 hp	36.4 kW
Fuel Tank Capacity	16 gal.	60.6 L

Hydraulic System

System Capacity	17.3 gal.	65.5 L
Tank Capacity	15 gal.	56.8 L
Auxiliary Power	12V-DC	

Tires

Standard	33/1550 x 16.5 Foam Filled Lug Tread
Optional	Non Marking Foam Filled Tires



Standard Features

- 4 ft 1 in. (1.24 m) Articulating Jib
- Platform 30 x 72 in. (0.76 x 1.83 m) Side Entry
- 180 Degree Hydraulic Platform Rotator
- Platform Console Machine Status Light Panel¹
- 110V-AC Receptacle in the Platform
- 5 Degree Tilt Alarm/Indicator Light
- Swing Out Engine Module
- Improved Multi-Function Controls
- Gull-Wing Turntable Hoods
- 12V-DC Auxiliary Power
- Hourmeter
- Interactive Display at Ground Controls
- Proportional Controls
- Control ADE® System
- Lifting/Tie Down Lugs
- Horn
- Four-Wheel Hydrostatic Drive
- Oscillating Axle
- Cast Aluminum Control Box
- Motion Alarm
- Reduced Time to Full Height
- Load Sensing System
- SkyGuard SkyLine™

Accessories & Options

- 30 x 60 in. (0.76 x 1.25 m) Platform
- Inward Self-Closing Swing
- 36 x 72 in. (0.91 x 1.83 m) Platform
- Fall Arrest Platform 30 x 60 in. (76 x 1.53 m)
- 1/2 in. Air Line to Platform
- SkySense®
- Soft Touch System
- AC Generator
- Flashing Amber Beacon
- 43.5 lb (19.73 kg) Propane Tank
- Cold Weather Kit²
- Hostile Environment Kit³
- Arctic Package⁴
- Light Package⁵
- Operator Tool Tray
- Accessory Packages
 - SkyPower® Package
 - SkyWelder® Package

1. Provides indicator lights at platform control console for system distress, low fuel, 5 degree tilt light, and foot switch status.
 2. Includes battery blanket, hydraulic tank heater, block heater (GM), glow plugs (Deutz).
 3. Includes boom wipers, cylinder bellows and console cover.
 4. Includes arctic hydraulic hoses (drive and steer only) and main boom cable, extreme cold engine oil, fuel conditioner, engine block heater, battery blanket, glow plugs, hydraulic tank heater, and oversized footswitch.
 5. Includes platform work lights, head and tail lights, amber beacon.

Note: Some options may increase lead time, and some option combinations may not be available. Additional accessories and options available via JLG Aftermarket.

450 SERIES

ARTICULATING BOOM LIFT



Dimensions

All dimensions are approximate.

450A

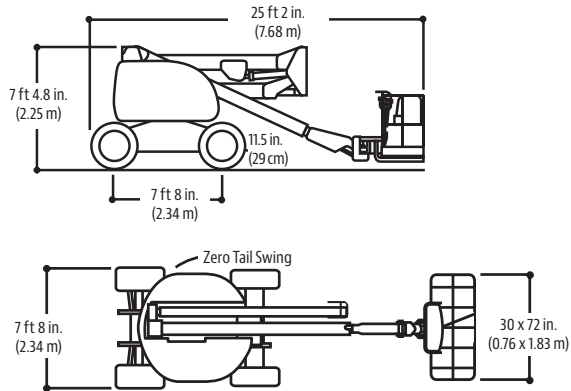

450AJ

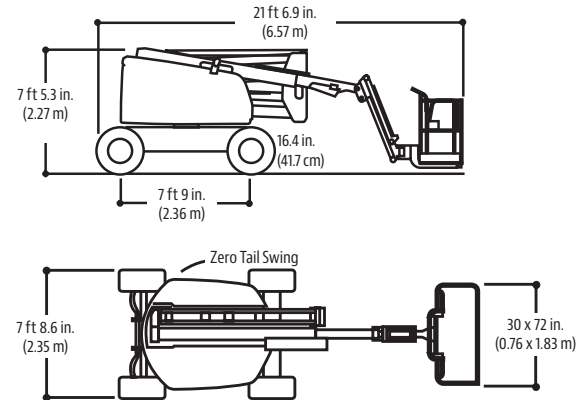

Reach Diagrams

450A

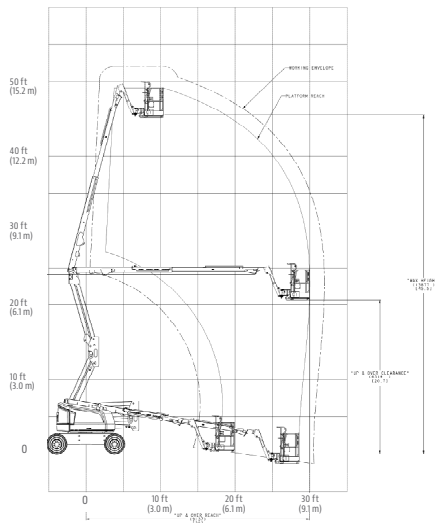

450AJ

